

EVA-LAST®

INSPIRED BY NATURE, DESIGNED FOR LIFE.



Sustainable Building Materials



Intertek



www.eva-last.co.uk



BSW
Composites

BSWGROUP member of binderholz



A BRAND YOU CAN TRUST

Eva-Last is a globally reputable brand that utilises a solution driven business model to create innovative, sustainable building materials and systems that add value to customers' lives. At the heart of Eva-Last is a team of highly capable, creative specialists united by a passion to promote environmental consciousness through eco-friendly building products and operations. By embracing low environmental impact manufacturing and cutting-edge composite technology, Eva-Last is revolutionising how building can be done. We design and deliver beautiful, long-lasting green alternatives that make our customers' lives easier, healthier, and just plain better.

THE HASSLE-FREE ALTERNATIVE TO WOOD

Eva-Last composite offers the beauty of timber, but in a hassle-free, durable option that's longer lasting, virtually maintenance free, and eco-friendly. Cutting-edge engineering is bringing even greater structural advancements and lifestyle benefits to composite, and thoughtful detail to aesthetics now gives it an even more natural appearance in an expanded range of products, colours, and textures.

PRODUCT CATEGORIES

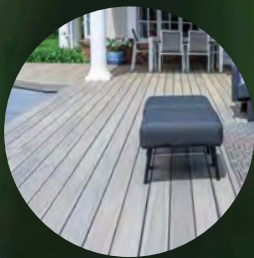

DECKING



CLADDING



RAILING



FASTENERS

Eva-Last technologies create endless possibilities for the design and overall function of your outdoor space. Visit our website, www.eva-last.com, for inspiration and find out more about which composite product will suit your needs best.

Featured: Infinity IS, Tiger Cove





LOW ENVIRONMENTAL IMPACT

Holistically sustainable manufacturing & use of raw materials

When you choose Eva-Last, you're choosing the best solution for both you and the environment. Eva-Last products are the low-maintenance, reliable alternative to wood that consistently outperform timber and other composite materials. They're also the environmentally friendly material choice that is gentler on the Earth.



BAMBOO WASTES LESS & PROVIDES MORE

Eva-Last uses bamboo in its composite production. Bamboo can grow up to 50 times faster than timber and releases 35 percent more oxygen into our air than most hardwood trees. It can be made into composite with only 2 percent wastage (compared to over 80 percent wastage with timber), and is naturally antibacterial.



USE OF RECYCLED PLASTIC

By using recycled waste plastics, in combination with easily replenishable bamboo fibre, we are able to produce a highly durable composite product while saving millions of tons of plastic from entering landfills and oceans. Every year Eva-Last recycles over 26000 tons of plastic. Recycling one ton of plastic results in carbon dioxide savings of approximately 0.73 tons – the same as travelling 4 000 km in a car.



USE OF SOLAR POWER IN THE MANUFACTURING PROCESS

Traditional manufacturing is an energy-intensive endeavour. That's why Eva-Last took the decision to start moving towards manufacturing using solar energy. Since 2017, 32 858 solar panels, or 88 716 m² of solar panels, have been installed. This leads to a saving of 2 000 tons of CO₂, every single day.

Eva-Last has been at the forefront of the green building industry since its inception in 2007. We are dedicated to consistently improving how we serve the environment and our clients. From the recycled and renewable raw ingredients we use to create our products, to the solar power we harness to manufacture, we are proud to offer holistically sustainable building products.

Holistically sustainable building products, from a globally reputable brand

TECHNOLOGIES

Eva-Last has developed a resilient collection of bamboo composite technologies, each with its own unique characteristics and set of benefits. These versatile materials can be used in a variety of applications such as decking, cladding, screening, railing, and architectural beams.



Apex

CAPPED BAMBOO FOAMED-PVC COMPOSITE

The Apex range boasts an exceptionally natural looking dual-tone finish and is also available in reinforced Apex PLUS for increased strength.



Infinity

CAPPED BAMBOO COMPOSITE

Infinity leads the Eva-Last technology range in durability with a resilient polymer capping, and bamboo composite core.

Disclaimer:

Although we make every effort to ensure the information contained in this brochure is accurate, we are NOT responsible for any errors or misprint that occurs and we are NOT responsible for ANY damage or liability that result from the use (or misuse) of the information. In the event that an error does occur, we reserve the right to correct, or make changes to, this information at any time.

Disclaimer:

Span data provided herein is indicative based on specific test load conditions (refer to your product Technical Data Sheet). Dimensional and mass data provided herein is indicative based on typical production and may vary with manufacture and material tolerance. Before installing any Eva-Last product, ensure that the application is rational and complies with the local regulations and building codes. Wherever necessary, consult a suitably qualified professional.

Apex

LIGHTWEIGHT, CAPPED BAMBOO-PVC COMPOSITE

Apex offers you a resilient and natural looking composite. Its ultra-lightweight bamboo foamed-PVC core makes for easy installation and workability. Apex carries both fire and slip resistance ratings and exceptional low maintenance, requiring only basic cleaning for optimal longevity. Its protective cap is made from a resilient acrylic polymer coating for fade, scratch, and stain resistance. Apex provides long-term decay and weather protection by resisting insects, moisture, and the elements. Apex is an eco-friendly alternative to timber that prevents deforestation and premature deck replacement and uses solar power within the manufacturing process.

PRODUCT COMPOSITION

Apex

Apex products are lightweight thanks to their foamed bamboo-PVC composite core which is protected from the elements by a resilient acrylic polymer capping.



Capping material:
Engineered acrylic polymer

Core material:
Bamboo foamed-PVC
composite



EUROCLASS B_{fl} - s1
FIRE RATED





Featured: Apex, Amariillo Oak

TAKE HOME THE BENEFITS



NATURAL AESTHETIC

Advanced technology for more natural looking composite



LIGHTWEIGHT

Ultra-lightweight bamboo-PVC core



FIRE RESISTANT

Euroclass B_{fl} - s1 fire rated



SLIP RESISTANT

Reliable slip resistance properties



LOW-MAINTENANCE

Only basic care required for optimal longevity



PROTECTIVE CAP

Fade, scratch, & stain resistant capping technology



DECAY RESISTANT

Resists insects, moisture, & weather



ECO-FRIENDLY

Long-lasting & prevents deforestation

LIGHTWEIGHT, CAPPED BAMBOO-PVC COMPOSITE

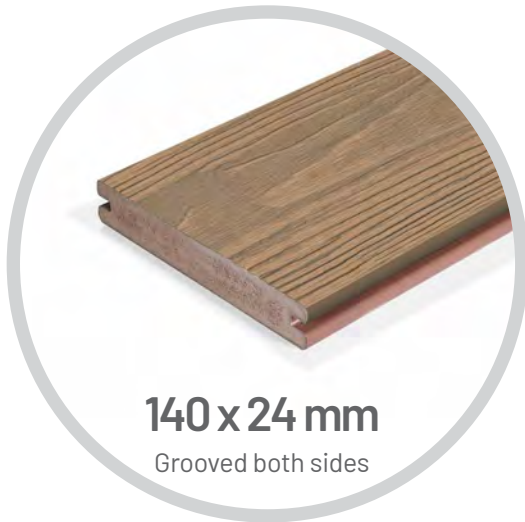

140 x 24 mm
Grooved both sides

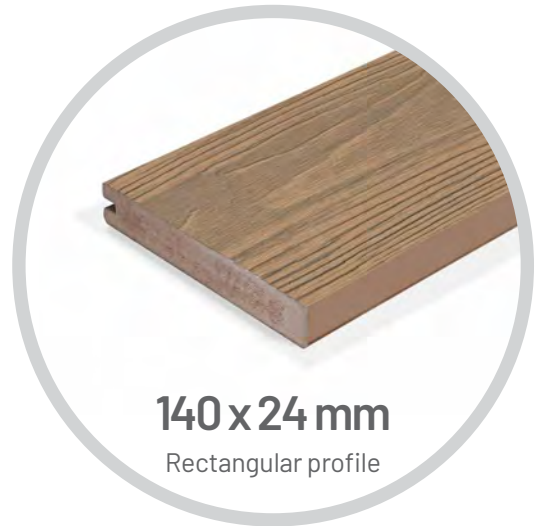

140 x 24 mm
Rectangular profile

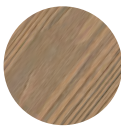

SCULPTED GRAIN

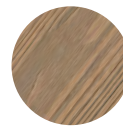

SCULPTED GRAIN

GROOVED BOARD

The Apex single sided grooved board installs efficiently and securely with Hulk hidden fastener clips which slot into the grooves along the edges of the board and create an uninterrupted final look.

| | |
|---------------------------|--|
| Dimensions | 140 x 24 mm (4,8 m lengths) |
| Weight | 2.5 kg/m |
| Recommended Joist spacing | 300 mm centre to centre* <i>*Please refer to the technical documents for more information on spans and loads.</i> |

Grooved board



Fasteners



Compatible with S-Series hidden clip and screw

STARTER BOARD

The Apex single sided starter board offers one grooved edge and one solid edge, making it perfect for deck perimeters, picture framing decks, and creating stairs. It fastens with a combination of Hulk hidden fastener clips and colour matched HULK composite decking screws.

| | |
|---------------------------|--|
| Dimensions | 140 x 24 mm (4,8 m lengths) |
| Weight | 2.5 kg/m |
| Recommended Joist spacing | 300 mm centre to centre* <i>*Please refer to the technical documents for more information on spans and loads.</i> |

Starter board



Fasteners



Compatible with S-Series hidden clip and screw



Uses HULK composite top fixing screws on non-grooved edges

Apex



LIGHTWEIGHT, CAPPED BAMBOO-PVC COMPOSITE



150 x 12 mm
Rectangular profile

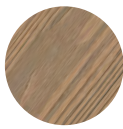

SCULPTED GRAIN

FASCIA BOARD

Apex fascia boards are non-load bearing profiles that help to add a neat finish to deck sides or areas where trim is needed. They are fastened using colour matching HULK top fixing composite trim screws.

| | |
|---------------------------|---|
| Dimensions | 150 x 12 mm (2,2 m lengths) |
| Weight | 1.4 kg/m |
| Recommended Joist spacing | 300 mm centre to centre* <i>*Based on non-load bearing applications only</i> |

Fascia board



Fasteners



Uses HULK top fixing screws



Featured: Apex, Amariillo Oak

PLEASE DOWNLOAD OUR LATEST TECHNICAL GUIDES



Technical Data Sheet



Installation Guide



Featured: Apex, Silver Birch

Apex

FINISH & COLOUR GUIDE

The dual tone range of Apex adds an extra layer of colour to each board to enhance the natural look of your composite project. The variance in shades within a single composite profile beautifully showcases the colour tones found in timber making your composite all the more striking. Dual tone colours are ideal for mid-to-large-scale composite decks and projects or other areas that are all about that natural look.

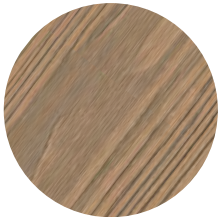

Sculpted Grain Surface Finish

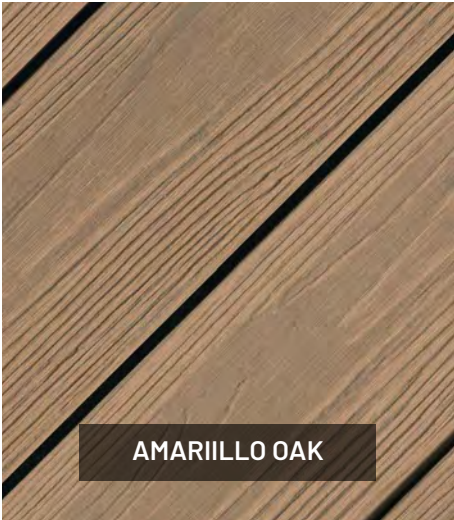

AMARIILLO OAK

Amariillo Oak available in:
140 mm Boards and
150 mm Fascia

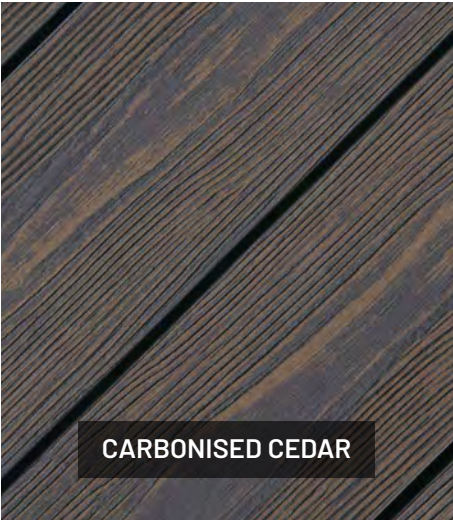

CARBONISED CEDAR

Carbonised Cedar available in:
140 mm Boards and
150 mm Fascia



SILVER BIRCH

Silver Birch available in:
140 mm Boards and
150 mm Fascia



Featured: Apex, Silver Birch

Apex



BAMBOO-PVC COMPOSITE JOIST



40 x 30 mm
Rectangular joist

FOAMED COMPOSITE JOIST

Apex foamed composite joists are a non-load bearing, cost-effective option for use over existing slabs such as screed, or tiled flooring, paving, and patios. Compared to standard deck installations, they are quick to install, requiring no posts or any other supporting structure.

| | |
|------------|----------------------------|
| Dimensions | 40 x 30 mm (2.2 m lengths) |
| Weight | 1.6 kg/m |
| Colour | Dark grey |



Fasteners

Lay spacers between the joist and the installation surface and then nail in anchors.





Featured: Apex, Amarillo Oak



Infinity **IS**

LIGHTWEIGHT, CAPPED BAMBOO COMPOSITE DECKING

Infinity IS combines all the benefits of durable Infinity bamboo composite with the advantages of I-Series to give you a durable co-extruded composite offering low maintenance, and an advanced resilient polymer cap for protection against scratches, fading, moisture issues, decay, and weather, as well as stain and slip resistance. With Infinity IS specialised streaked colour variation technology you can enjoy the look of timber in an environmentally friendly bamboo composite. The revolutionary I-beam design creates a cost-effective, lightweight board that uses less material, yet maintains span capabilities, strength, and stiffness for a more efficient installation. This improved environmentally friendly composite is holistically sustainable from its manufacturing to its use of raw material.



PRODUCT COMPOSITION



I-Series offers a cost-effective, lightweight decking option thanks to its revolutionary shape which uses less material but maintains class-leading strength, stiffness, and span capability.



(P) PATENTED TECHNOLOGY

Capping material:
Engineered polymer

Core material:
Bamboo PE composite



COST-EFFECTIVE
Smart shape saves on transport & installation



LIGHTWEIGHT
I-beam design is lighter by using less material



SPAN
Span capability of heavier boards



INSTALLATION
Easier and more efficient installation





Featured: Infinity IS, Pewter



TAKE HOME THE BENEFITS



DURABLE

One of the toughest co-extruded composites



PROTECTIVE CAP

Fade, scratch, & stain resistant capping technology



LOW-MAINTENANCE

Only basic care required for optimal longevity



DECAY RESISTANT

Resists insects, moisture, & weather



STAIN RESISTANT

Built-in protection against stains



SLIP RESISTANT

Reliable anti-slip protection



NATURAL LOOK

Specialised streaked colour technology



ECO-FRIENDLY

Sustainable manufacturing & use of raw material

LIGHTWEIGHT, CAPPED BAMBOO COMPOSITE DECKING



135 x 25.4 mm
Grooved both sides



135 x 25.4 mm
Grooved one side



SCULPTED GRAIN



SCULPTED GRAIN

GROOVED BOARD

The Infinity IS single sided grooved board installs efficiently and securely with HULK hidden fastener clips which slot into the grooves along the edges of the board and create a neat uninterrupted final look.

| | |
|---------------------------|--|
| Dimensions | 135 x 25.4 mm (4,8 m lengths) |
| Weight | 2.8 kg/m |
| Recommended Joist spacing | 500 mm centre to centre* <i>*Please refer to the technical documents for more information on spans and loads.</i> |

Grooved board



Fasteners



Compatible with S-Series hidden clip and screw

STARTER BOARD

The Infinity IS single sided starter deck board offers one grooved edge and one solid edge, making it perfect for deck perimeters, picture framing decks, and creating stair edges. It fastens with a combination of HULK hidden fasteners and colour matched HULK composite decking screws.

| | |
|---------------------------|--|
| Dimensions | 135 x 25.4 mm (4,8 m lengths) |
| Weight | 2.7 kg/m |
| Recommended Joist spacing | 500 mm centre to centre* <i>*Please refer to the technical documents for more information on spans and loads.</i> |

Starter board



Fasteners



Compatible with S-Series hidden clip and screw



Uses HULK composite top fixing screws on non-grooved edges

CAPPED BAMBOO COMPOSITE FASCIA

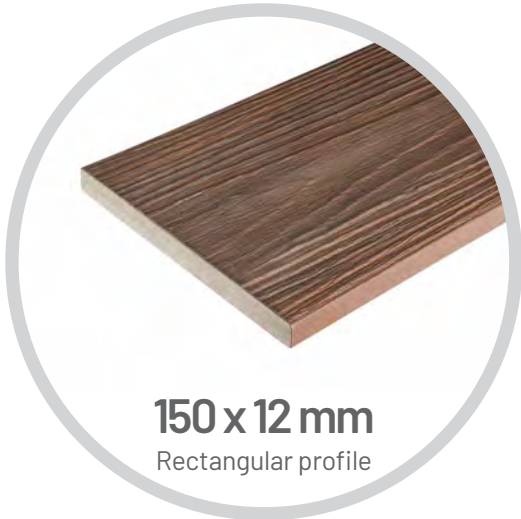

150 x 12 mm
Rectangular profile



SCULPTED GRAIN



BRUSHED SOFTWOOD

FASCIA BOARD

The Infinity single sided fascia boards are non-load bearing profiles that add a neat finish to deck edges or areas where trim is needed. They are neatly fastened by top fixing colour matching HULK composite trim screws.

| | |
|---------------------------|---|
| Dimensions | 150 x 12 mm (2,2 m lengths) Double sided; Brushed softwood Sculpted grain |
| Weight | 2.3 kg/m |
| Recommended Joist spacing | 400 mm centre to centre* <i>*Based on non-load bearing applications only</i> |

Fascia board



Fasteners



Uses HULK composite screws



Featured: Infinity IS, Pewter

PLEASE DOWNLOAD OUR LATEST TECHNICAL GUIDES



Technical Data Sheet



Installation Guide



Featured: Infinity IS, Rustic Oak

Infinity

FINISH & COLOUR GUIDE

The Infinity range is designed to enhance the beauty and liveability of your outdoor area. Infinity composite offers incredibly natural-looking colours thanks to its advanced colour technology which gives each board unique colour variation to embody the essence of timber. Enjoy the beauty of wood with the benefits of composite.



Sculpted Grain Surface Finish



Brushed Softwood Surface Finish
(Fascia only)



RUSTIC OAK

Rustic Oak available in:
135 mm Boards
and 150 mm Fascia

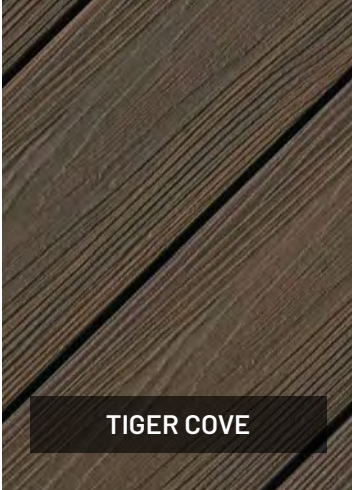

TIGER COVE

Tiger Cove available in:
135 mm Boards
and 150 mm Fascia



PEWTER

Pewter available in:
135 mm Boards
and 150 mm Fascia

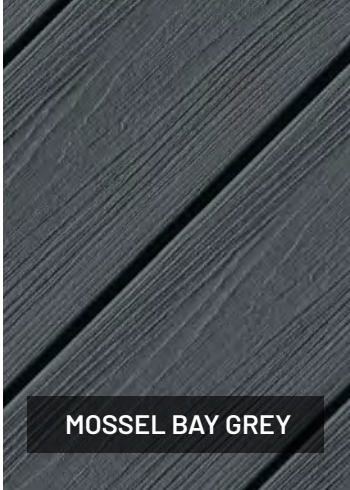

MOSSSEL BAY GREY

Mossel Bay Grey available in:
135 mm Boards
and 150 mm Fascia



Featured: Infinity IS, Tiger Cove





ADVANCED COMPOSITE CLADDING

The VistaClad lightweight bamboo composite cladding system is revolutionising how cladding works with an innovative clip strip which locks boards into place using reliable dual spring technology. VistaClad is available in a range of colours and finishes, with trim and accessories, as a complete cladding system, designed for ease of installation. Backed by an industry-leading warranty, this low-maintenance, weather-resistant cladding is a smart, cost-efficient investment in your project and a sustainable investment in our planet.



VISTA CLAD SYSTEM COMPONENTS

The VistaClad system combines Eva-Last composite technologies with an innovative installation process to provide a robust and convenient cladding solution. The resultant hidden fixing generates an unblemished finish and avoids the limitations or inconvenience of fastening through composite.



Composite Cladding Boards



Clip Strip



Adapters and Trim Profiles

CUTTING-EDGE SUSTAINABLE CLADDING

VistaClad bamboo composite cladding breathes vibrancy into your home or office space and enhances your walls with the attractive look of natural hardwoods. Let routine maintenance and premature replacement be things of the past as you look to the future with one of the most cutting-edge cladding systems available, complete with complementary trim for a neat and tidy finish.



Featured: Apex, Natural Cedar

TAKE HOME THE BENEFITS



CLIP LOCK DESIGN

Boards securely click & lock into place to withstand strong winds



COMPLETE CLADDING SOLUTION

Innovative system with concealed fastening & trim for a finished look



LIGHTWEIGHT

Smart system engineered for lighter weight & better airflow



VENTILATED & INSULATED

Design allows for system ventilation & natural insulation



LOW-MAINTENANCE

Ideal for large-scale projects & application at height



DECAY RESISTANT

Resists biodegradation, corrosion, insects, UV, & harsh weather



COST-EFFECTIVE SYSTEM

Save on fast, simplified installation & overall upkeep



ECO-FRIENDLY

Sustainable manufacturing & use of raw materials

VISTA CLAD CLADDING IN APEX BAMBOO-PVC COMPOSITE

VistaClad is available in Apex bamboo-PVC composite. Backed by a 30-year warranty, Apex lightweight, capped composite is an ideal cladding material. The dual colour finish of Apex provides an exceptionally natural looking composite which embodies the essence of timber in a range of nuanced shades to complement your overall project. Install this environmentally friendly, low-maintenance cladding vertically or horizontally to suit your style.

Apex



BAMBOO-PVC CLADDING MATERIAL

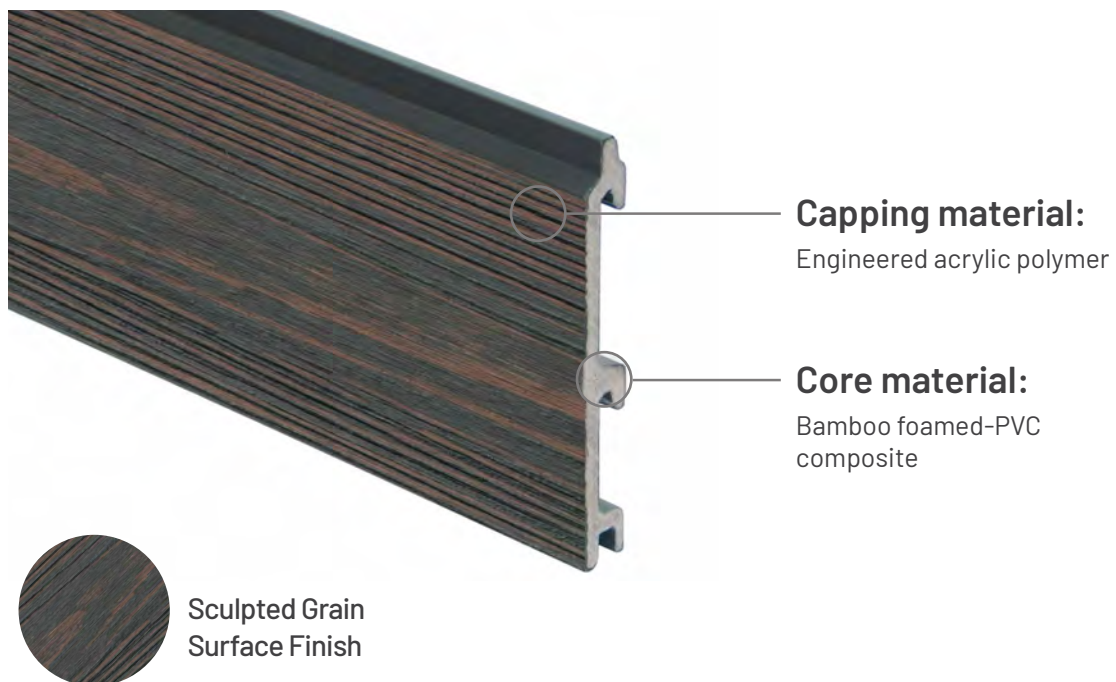

APEX BAMBOO FOAMED-PVC CLADDING

| Cross section | Product description | Dimensions | Coverage | Mass |
|---|---------------------|-------------------------------|--------------------|----------|
|  | Standard | 163 x 20.5 mm (4.8 m lengths) | 6.6 m ² | 1.5 kg/m |



TECHNOLOGY: **Apex**

VISTA CLAD IN APEX DUAL TONE COLOUR TECHNOLOGY

The Apex dual tone colour range offers a sculpted grain finish for more natural looking cladding. Each cladding board has an extra layer of colour added to create the subtle variances found in timber. The sculpted grain finish produces a texture that embodies the look of wood to give your exterior walls the beauty of timber cladding in a more resilient, low-maintenance, and eco-friendly composite option.

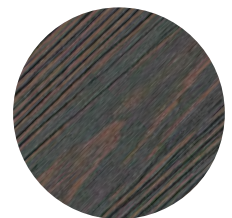

Sculpted Grain
Surface Finish



SILVER BIRCH



NATURAL CEDAR

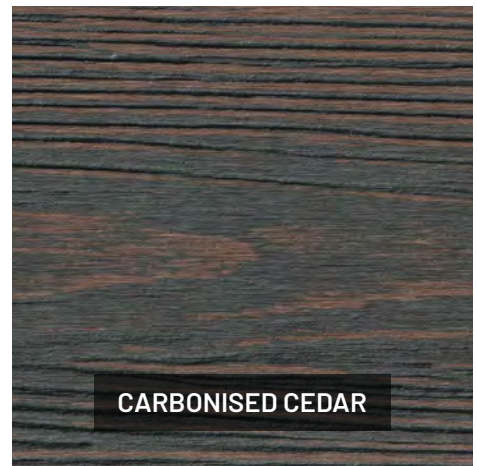

CARBONISED CEDAR

VISTA CLAD CLADDING IN INFINITY BAMBOO COMPOSITE

VistaClad cladding boards in Infinity co-extruded capped bamboo composite offer exceptional durability. The hardy bamboo PE (polyethylene) composite core is wrapped in a robustly engineered polymer cap for a resilient composite. Infinity offers a low-maintenance, eco-friendly alternative to conventional cladding in a selection of natural finishes. Enjoy its resistance features, such as protection against scratches, fading, moisture, insects, and weather, all backed by a 25-year warranty.

Infinity



BAMBOO COMPOSITE CLADDING MATERIAL



Capping material:
Engineered polymer

Core material:
Bamboo PE composite



Brushed Softwood
Surface Finish

INFINITY BAMBOO COMPOSITE CLADDING

| Cross section | Product description | Dimensions | Coverage | Mass |
|---|---------------------|-------------------------------|--------------------|----------|
|  | Standard | 163 x 20.5 mm (4.8 m lengths) | 6.6 m ² | 2.0 kg/m |



TECHNOLOGY: *Infinity*

VISTA CLAD IN INFINITY STREAKED COLOUR TECHNOLOGY

The Infinity colour range offers specialised streaked colour technology to ensure that no two cladding boards are identical and to give your exterior walls the look of natural timber cladding. The brushed finish applied to the VistaClad Infinity cladding boards further enhances the natural tones, allowing you to enjoy the look of timber cladding in a more durable, hassle-free, and sustainable bamboo composite.



Brushed Softwood
Surface Finish

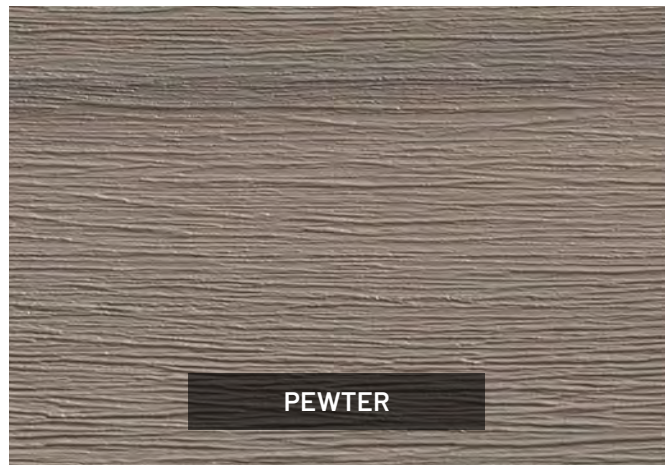
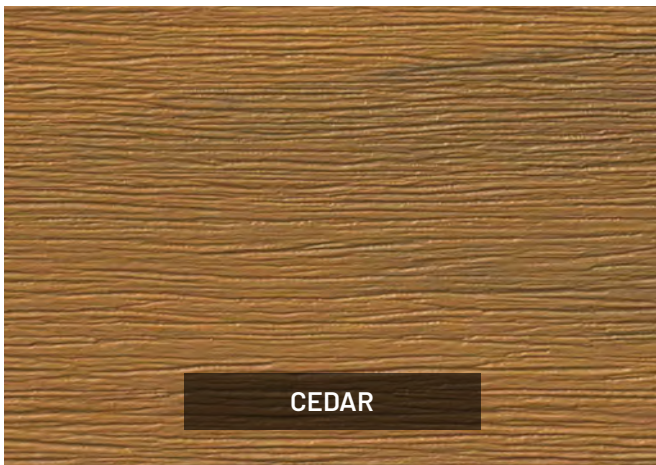



THE CLIP STRIP

The VistaClad clip strip uses a punched spring design that allows the cladding boards to be easily and securely clicked into place. Three epoxy-coated, zinc-galvanised strip profile options provide flexibility in application and allow for optimal ventilation and drainage.

The dual spring-loaded clip creates a rigid hold and locks the boards in place.



FLAT CLIP STRIP

The flat clip strip is fitted directly to the wall substrate or frame. As a result, this solution provides the smallest ventilation/drainage cavity and fixing can only be done through the face of the clip strip.

| | |
|------------|------------------------------|
| Dimensions | 40 x 11.7 mm (1.8 m lengths) |
| Weight | 0.4 kg/m |



NYLON ADAPTORS



Top & bottom adaptor



Side adaptor



Internal corner adaptor



External corner adaptor

ALUMINIUM TRIM PROFILES



Universal trim profile
5.8 m



T trim profile
2.9 m



Minimal U trim profile
2.9 m



Internal corner
trim profile
2.9 m



External corner
trim profile
2.9 m

TRIM APPLICATIONS

Trim accessories hide the structure for a neat final look and can be installed using sealing strips to improve the weather resistance of the cladding surface. The clip strip allows for easy guided placement of the adaptors and the universal trims may be used with VistaClad or any cladding boards with a thickness of 20.5 to 26.5 mm.



Top, bottom and side adaptors with universal trim profile

Top and bottom and edge applications



Window applications

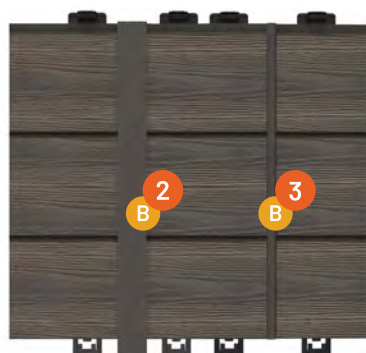

Side adaptor with T trim profile

Side adaptor with minimal U trim profile

Butt join applications

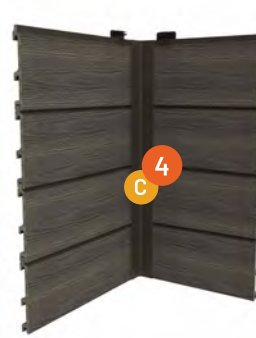

Internal corner adaptor with internal corner trim profile

External & internal corner applications



External corner adaptor with external corner trim profile

RAPIDRAIL

INTEGRATED RAILING SYSTEM

INTEGRATED COMPOSITE RAILING SYSTEMS

RapidRail eco-friendly composite railing offers long-lasting reliability and safety in a selection of natural colours and styles, and is designed to work with a variety of decking materials and accessories. As its name suggests, RapidRail installs rapidly and easily using smart configurations which reduce the number of connections required. Available in Infinity or Eva-tech composite technologies by Eva-Last, RapidRail offers protection from insects, moisture issues, decay, and harsh weather.

SAFER, STRONGER, STUNNING RAILING

RapidRail combines safety and artistry for a composite railing system that makes your space more functional, more secure, more appealing, and virtually maintenance free. Make your deck a truly liveable space with innovative railing that provides a strong sense of security and promotes a more hassle-free way of life.

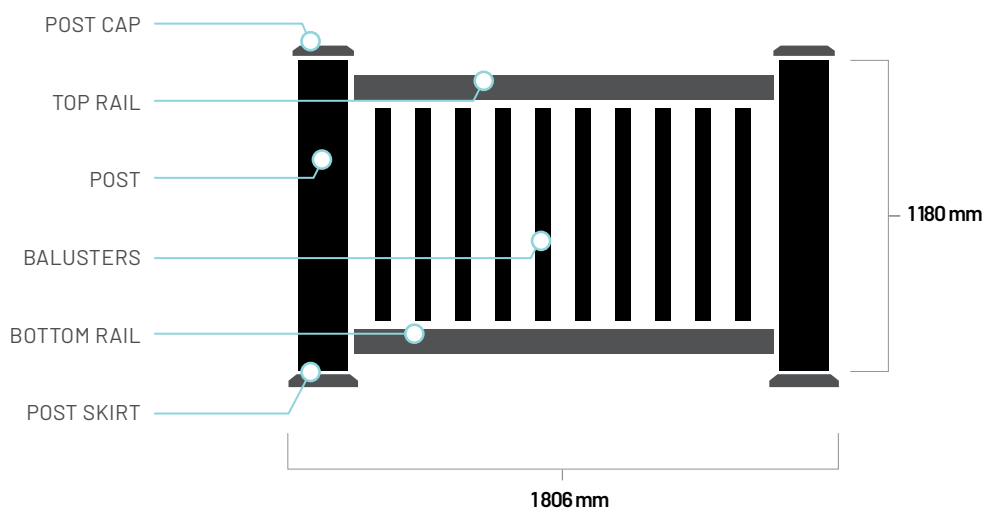



TAKE HOME THE BENEFITS

TECHNOLOGY: *Infinity*[®]



LOW MAINTENANCE

Requires only the most basic of cleaning for optimal longevity



MOISTURE RESISTANT

Protection from mould, mildew, rot, & other moisture issues



INSECT RESISTANT

Protection from damage caused by termites & other insects



RAPID & EASY INSTALLATION

Designed for precise, efficient, & cost-effective installation



FULLY CUSTOMISABLE

Compatible with other railing styles & materials



ECO-FRIENDLY

Holistically sustainable manufacturing & use of raw materials



RAPIDRAIL

INTEGRATED RAILING SYSTEM



TECHNOLOGY: *Infinity*[®]

INFINITY CAPPED BAMBOO COMPOSITE RAILING

RapidRail balustrades are available in Infinity composite technology by Eva-Last. The bold black colour is thoughtfully created with an advanced protective capping technology to allow for an impressive aesthetic appeal along with the benefit of Infinity's ultra durable and low-maintenance characteristics.

RAPIDRAIL FINISH

Brushed Soft Wood

| Product | Colour | Dimensions |
|-------------------|--------|--|
| Composite Beam | Black | 89 x 38 x 1600 mm |
| Composite Post | Black | 102,5 x 102,5 x 1185 mm |
| Nylon Cap & Skirt | Black | To fit the 102,5 x 102,5 (post) x 45,5mm |
| Composite Newel | Black | 35 x 35 x 870mm |





HULK FASTENERS.

RELIABLE DECKING FASTENER SYSTEMS

HULK Fasteners are purposefully designed to make composite or timber decking installations more efficient and straightforward by providing highly durable hidden fastener options that fit neatly into the edges of grooved boards, as well as a range of colour matching top fixing screws. These fasteners are created to match the warranties of the leading composite decking boards on the market, and are available in a range of colours to complement the look of your decking of choice.

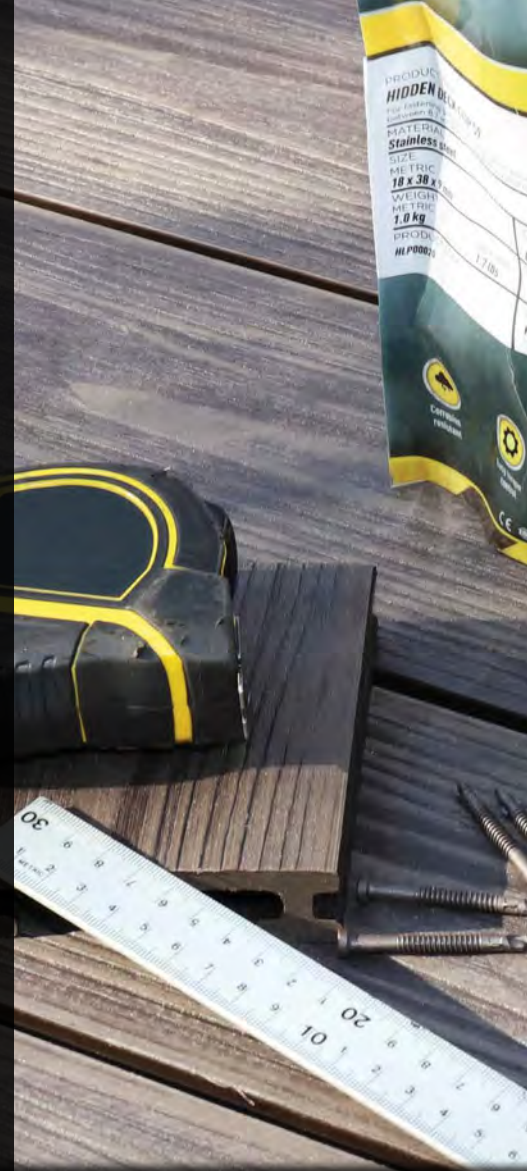

DESIGNED FOR PROFESSIONALS. PERFECT FOR NOVICES.

HULK Fasteners offer higher performance and are a more efficient and subtle way to secure your decking and trim boards without disrupting its final look.

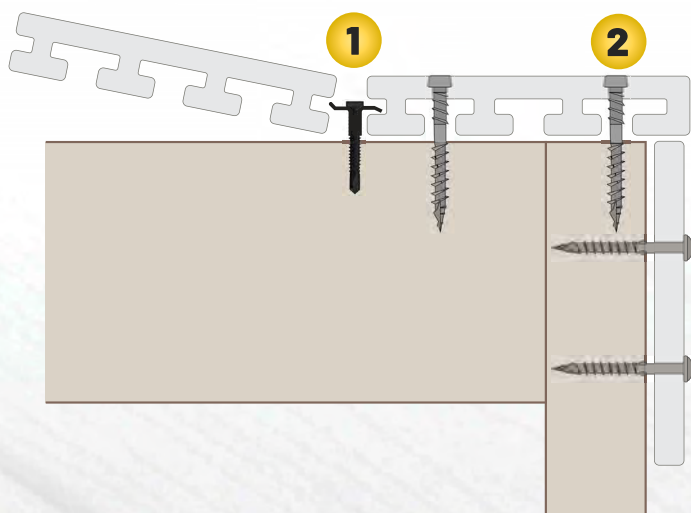

- 1 Hidden Clip & Clip Screw
- 2 Composite Decking Screw (CDS) for timber frames or Metal Decking Screw (MDS) for metal frames



TAKE HOME THE BENEFITS



**Corrosion
Resistant**



**Colour Matched
Aesthetic**



**Neat Surface
Finish**



**Fast and Easy
Installation**



**No Pre-drilling
Required**

S-SERIES CLIP

Eva-Last created the S-Series (Halo) clip in 2010, designed to match the life expectancy and durability of Eva-Last composite decking materials. This product laid the foundation for the hidden fastener: no more protruding screws, no more ruined finishes, no more untidy aesthetics.

S-SERIES HIDDEN DECKING CLIP

S9 CLIP

Use for fastening grooved deck boards with a foot height of approximately 9 mm; compatible with metal and timber clip screws



CLIP SCREWS

METAL CLIP SCREW

CS
CARBON
STEEL
C1022



Designed to fasten HULK hidden deck clips onto metal frames without having to pre-drill (on metal frames 2 mm thick or less)



COMPATIBLE WITH S-SERIES CLIP

TIMBER CLIP SCREW

SS
STAINLESS
STEEL
SS316



For fastening HULK hidden deck clips onto timber frames without having to pre-drill

CS
CARBON
STEEL
C1022

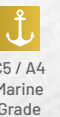

C5 / A4
Marine
Grade







COMPATIBLE WITH S-SERIES CLIP

COLOUR MATCHED COMPOSITE TOP FIXING SCREWS

HULK Fasteners composite deck and trim screws are available in nine different colours designed to match and blend in with decking boards from all leading composite decking manufacturers. Choose the colour that matches your decking boards for a discreet final look. Please check your regional availability of screw colours.

SCREW COLOURS

| COLOUR |  |  |  |  |  |
|----------|---|---|---|---|---|
| | LIGHT GREY | DARK GREY | BEIGE | TAN BROWN | BROWN |
| APEX | Silver Birch | Carbonised Cedar | - | Amarillo Oak | - |
| INFINITY | - | Mossel Bay Grey Pewter | Rustic Oak | - | Tiger Cove |



S-SERIES clip and screw combo packs

STARTER KITS



5 m² HULK EXPANSION KIT

- S9** 90 Stainless steel clip screws
- 90 Stainless steel Halo clips
- 1 Drill bit



EXPANSION KITS



10 m² HULK EXPANSION KIT

- S9** 180 Stainless steel clip screws
- 180 Stainless steel Halo clips
- 1 Drill bit



75 COMPOSITE DECK & COMPOSITE TRIM SCREWS



75 TOP FIXING SCREWS

- 75 Stainless steel composite DECK and/or TRIM screws
- 1 Drill bit



Recommended for use with all Eva-Last® installations, HULK composite deck and trim screws are available for timber and metal frames



LOW ENVIRONMENTAL IMPACT

Holistically sustainable manufacturing & use of raw materials

CHOOSE SUSTAINABLE BUILDING MATERIALS



RENEWABLE RESOURCES & RENEWABLE ENERGY

We believe that how we manufacture is just as important as what we manufacture when it comes to going green. That's why we've traded in fossil fuels for renewable energy. Our products use solar power as part of our manufacturing process. We are fully committed to bringing you a product that's holistically sustainable.

Every Eva-Last outdoor range pairs recycled raw ingredients with bamboo for a stronger, more sustainable composite. Bamboo rejuvenates over 30 times faster than traditional hardwoods and it releases 35% more oxygen into our air. Eva-Last is internationally recognised for our commitment to the environment. We're proud of the work we do to promote environmental sustainability, and invite you to choose timber alternatives that are gentle on the Earth.

- Made from recycled materials
- No trees felled
- No treatment or toxic chemicals required for maintenance
- Solar power used in the manufacturing process
- Reduced impact on landfills
- Reduced carbon footprint



BSW
Composites

BSWGROUPO member of binderholz

England & Wales:

Tel: 0800 0234322 | sales@bswtimbersolutions.co.uk

Scotland:

Tel: 0800 5878887 | sales@bsw.co.uk

EVA-LAST[®]
INSPIRED BY NATURE, DESIGNED FOR LIFE.



www.eva-last.co.uk